

1-2295018-2 ✓ 有效

TE 内部编号 1-2295018-2

TE 内部产品描述 USB TYPE C, REC OFFSET 0.65MM DUAL SMT

[在 TE 官网查看>](#)



连接器 > 音频和视频连接器 > USB 连接器



USB 类型: C

USB 版本: 3.1 gen 1

连接器种类: 母端

端口数量: 1

方向: 直角

## 产品特性

### 产品类型特性

整体式锁销	不带
接地选项	面板接地
接地元件类型	M2 螺纹孔
USB 类型	C
USB 版本	3.1 gen 1
连接器种类	母端
方向	直角
连接器系统	缆到板
连接器和端子端接到	印刷电路板
产品类型	连接器

### 结构特性

面板接地位置	右/左
端口数量	1
Number of Positions	24

### 主体特性

偏移	.65 mm
外壳电镀涂层	亮光
外壳电镀材料	镍

### 接触件特性

端子额定电流 (最大值)	5 A
端子接触部电镀材料	镍镀金
端子接触部电镀厚度	.75 $\mu\text{m}$ [30 $\mu\text{in}$ ]

### 端接特性

端子端接类型	表面贴装
--------	------

### 机械附件

定位柱	不带
安装位置	中间安装
锁定特性	不带
连接器安装类型	板安装

### 壳体特性

中心线 (间距)	.5 mm[.019 in]
外壳材料	高温热塑性塑料
壳体颜色	黑色

### 使用环境

工组温度范围	-30 – 85 $^{\circ}\text{C}$ [-22 – 185 $^{\circ}\text{F}$ ]
--------	---

### 操作/应用

能够拾放	是
电路应用	Signal

### 包装特性

封装方法	磁带盘
------	-----

### 其他

应用方法	胶带
------	----

### 产品合规性

如需合规文档，请访问 [TE 官网产品页面](#)。>

欧盟RoHS指令2011/65/EU	符合
欧盟ELV指令2000/53/EC	符合
中国电器电子产品有害物质限制使用管理办法 (China RoHS 2, 工业和信息化部携七部委2016年第32号令)	没有超出阈值的受限材料
欧盟REACH法规(EC) No. 1907/2006	欧洲化学品管理局最新发布的SvHCs候选清单: 2019年7月 (201)

SvHCs候选清单的声明更新至: 2017年7月  
(174)

不含REACH SVHC

欧盟REACH法规(EC) No. 1907/2006

欧洲化学品管理局最新发布的SvHCs候选清单: 2019年7月 (201)

SvHCs候选清单的声明更新至: 2017年7月  
(174)

卤素含量

低卤素 - 每种均质材料的 Br、Cl、F、I < 900 ppm。也不含 BFR/CFR/PVC

焊接工艺能力

回流焊接可达到 260°C

#### 产品合规免责声明

此信息基于对供应商的合理调查以及TE对供应商提供的信息的现有认知。此信息可能发生变化。经TE确认符合欧盟RoHS的产品编号，产品均质材料中铅、六价铬、汞、PBB、PBDE、DEHP、BBP、DBP和DIBP的最大浓度不超过0.1%，镉的最大浓度不超过0.01%或符合指令2011/65/EU(RoHS2)及其修订指令规定的豁免。根据2011/65/EU指令要求电子电气产品需要进行CE标识。元器件产品通常无需进行CE标识。经TE确认符合欧盟ELV指令的产品编号，产品均质材料中，铅、六价铬和汞的最大浓度不超过0.1%，镉的最大浓度不超过0.01%（按重量计算），或符合指令2000/53/EC(ELV)附录中规定的豁免。关于欧盟REACH法规，TE目前提供的物品中高度关注物质含量（SVHC）信息是基于欧洲化学品管理局（ECHA）“物品中物质的要求指南”（2011年4月第2版），在最终产品中高度关注物质含量按重量计算不超过0.1%。TE注意到欧洲法院在2015年9月10日的裁定（也被称为O5A：Once An Article Always An Article），对于“复杂物品”，高度关注物质含量阈值标准适用于产品本身以及组成产品的单个物品。TE已经基于新的ECHA“物品中物质的要求指南”（2017年6月第4版）完成对O5A规则的评估，并将相应更新REACH的声明。

## 客户还购买了





## 文档

### 产品图纸

[USB TYPE C, REC OFFSET 0.65MM DUAL SMT](#)

英文版本

### 目录页/数据表

[USB Type-C](#)

英文版本

[USB Type-C CN](#)

### 产品规格

[产品规格](#)

英文版本

### 产品环境合规性

[TE 材料声明](#)

英文版本

THIS DRAWING IS UNPUBLISHED. RELEASED FOR PUBLICATION 20  
COPYRIGHT 20 BY - ALL RIGHTS RESERVED.

REVISIONS				
P	LTR	DESCRIPTION	DATE	APVD
A		REVISED	07APR2017	A.X H.WU
A1		REVISED PER ECR-17-004423	13NOV2017	S.ZH S.L
B		REVISED PER ECR-18-010233	T.Z	S.L

SHOWN AS; 2295018-2

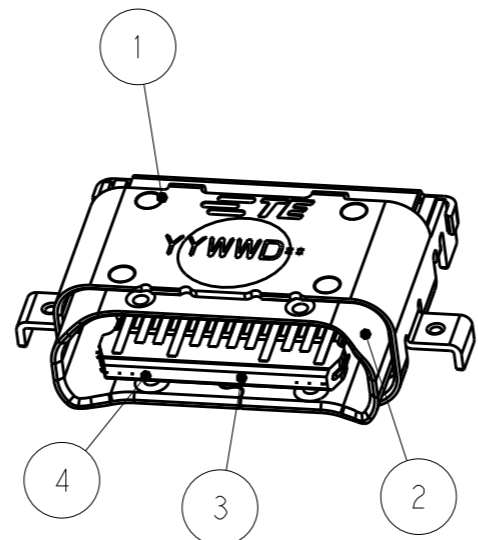
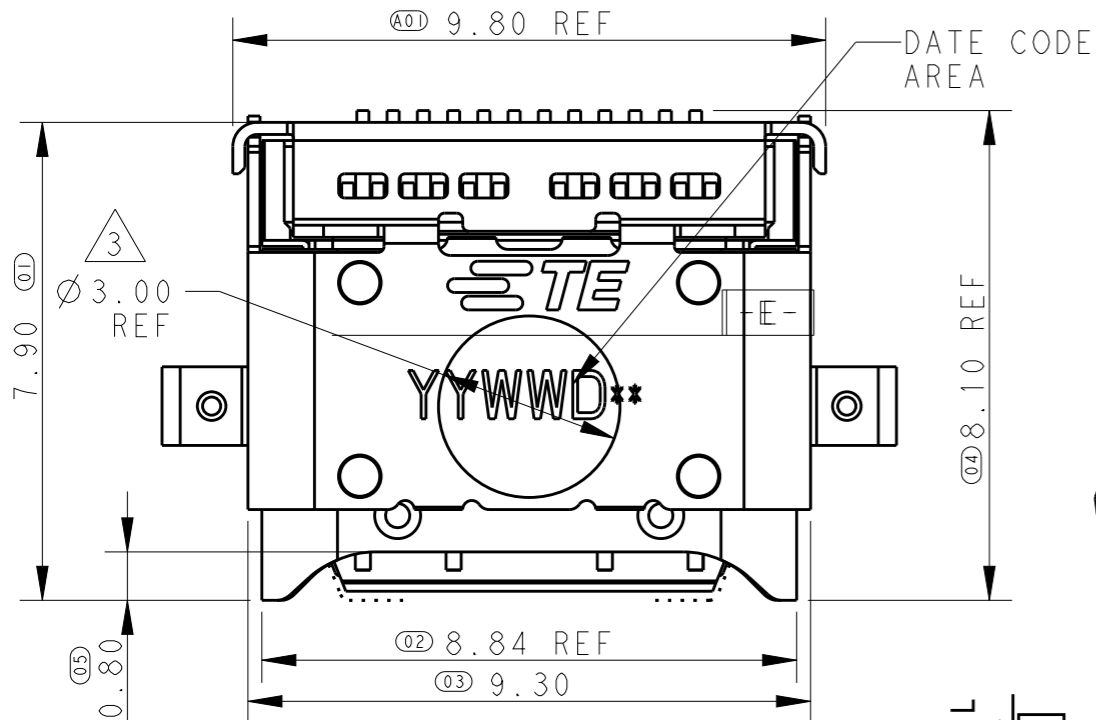

- NOTES:
- MATERIAL : SEE TABLE "A"
  - FINISH : SEE TABLE "A"
  - PICKING AREA
  - DATE CODE
  - FEATURES IDENTIFIED AS STATISTICALLY TOLERANCED (5)

DAY SHIFT OR NIGHT SHIFT  
 YYWWD\*\*  
 ASSY LINE NO. A,B,C,\*\*\*

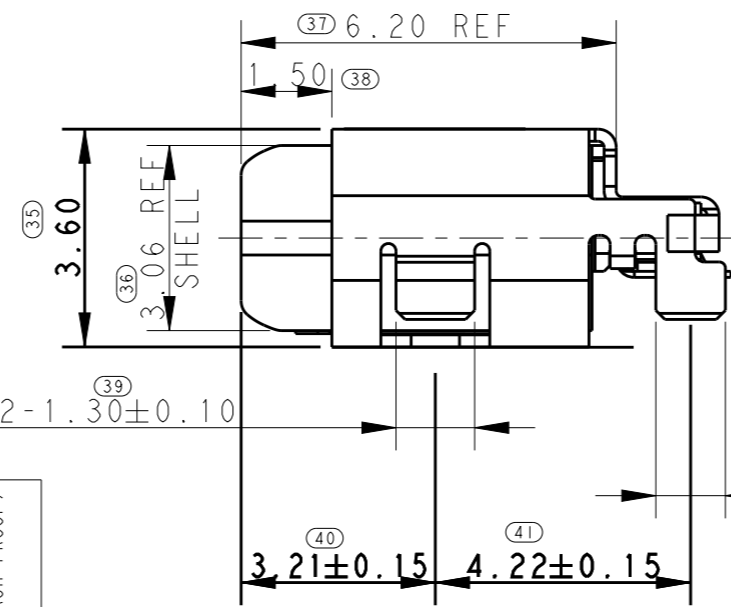
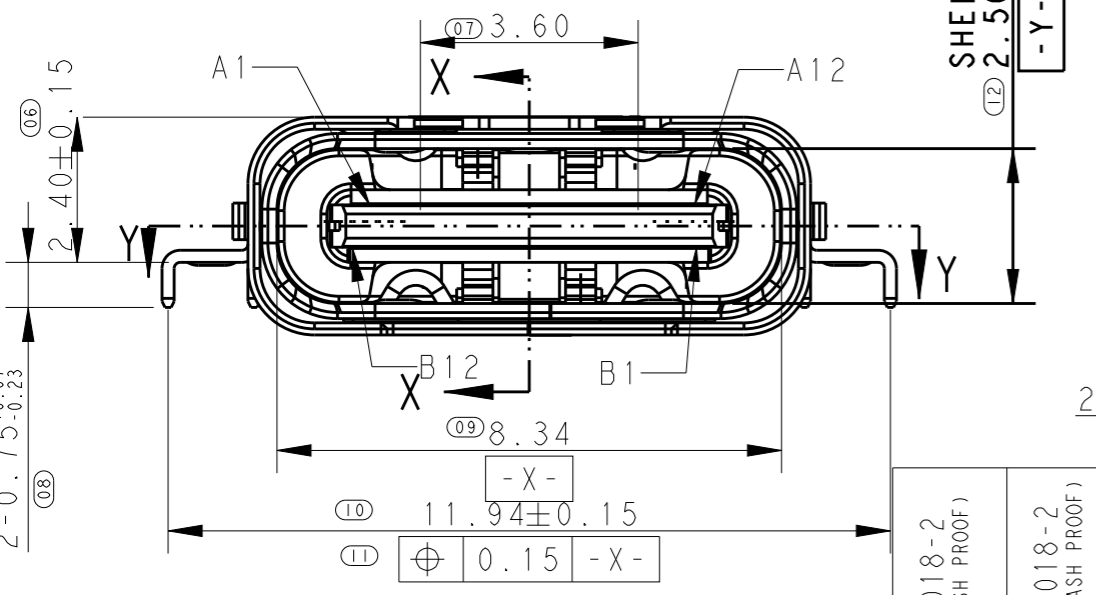

FOR ALL SMT CONTACT TAILS BEFORE REFLOW 0.08MAX. AFTER REFLOW 0.10MAX.

TABLE "A"

2295018-2 (SPLASH PROOF)  
 1-2295018-2 (NONE SPLASH PROOF)

ITEM	DESCRIPTION	MATERIAL AND FINISH	Q'TY	Q'TY
-	PACKAGE	-	-	-
11	POTTING	SILICONE	1	1
10	MYLAR	POLYIMIDE TAPE	1	-
9	LOWER CONTACT	ALLOY. CONTACT AREA:0.75um MIN Au PLATED. SOLDER AREA:GOLD FLASH.	1	1
8	UPPER CONTACT	ALL OVER:1.27 um MIN NI PLATED	1	1
7	LOWER CONTACT IM	HIGH TEMPERATURE PLASTIC,BLACK, UL94V-0	1	1
6	UPPER CONTACT IM	HIGH TEMPERATURE PLASTIC,BLACK, UL94V-0	1	1
5	INNER SHELL	STAINLESS STEEL, CLEANING	2	2
4	MID-PLATE	STAINLESS STEEL, OVER ALL, 1.27um MIN NI PLATED.	1	1
3	MAIN IM HOUSING	HIGH TEMPERATURE PLASTIC,BLACK, UL94V-0	1	1
2	MAIN SHELL	STAINLESS STEEL, OVER ALL, 1.27 um MIN NI PLATED.	1	1
1	BRACKET SHELL	STAINLESS STEEL, OVER ALL, 1.27 um MIN NI PLATED.	1	1

(5)

THIS DRAWING IS A CONTROLLED DOCUMENT.		DWN S.ZH 18AUG2015	TE Connectivity NAME USB C, RECEPTACLE, DUAL ROW SMT, OFFSET 0.65MM -	
DIMENSIONS: mm		CHK H.WU 18AUG2015		
TOLERANCES UNLESS OTHERWISE SPECIFIED:		APVD H.WU 18AUG2015		
0 PLC ±0.25 1 PLC ±0.25 2 PLC ±0.25 3 PLC ±0.25 4 PLC ±0.25 ANGLES ±3°		PRODUCT SPEC 108-115109-2		
MATERIAL SEE DRAWING		FINISH -	APPLICATION SPEC 501-115141-2	SIZE A3
-		-	WEIGHT -	CAGE CODE -
-		-	CUSTOMER DRAWING	DRAWING NO C-2295018
-		-	SCALE 1:1	SHEET 1 OF 4
-		-	RESTRICTED TO -	REV B1

THIS DRAWING IS UNPUBLISHED. RELEASED FOR PUBLICATION 20  
COPYRIGHT 20 BY - ALL RIGHTS RESERVED.

REVISIONS

P	LTR	DESCRIPTION	DATE	DWN	APVD
-	-	SEE SHEET 1	-	-	-

SHOWN AS; 2295018-2

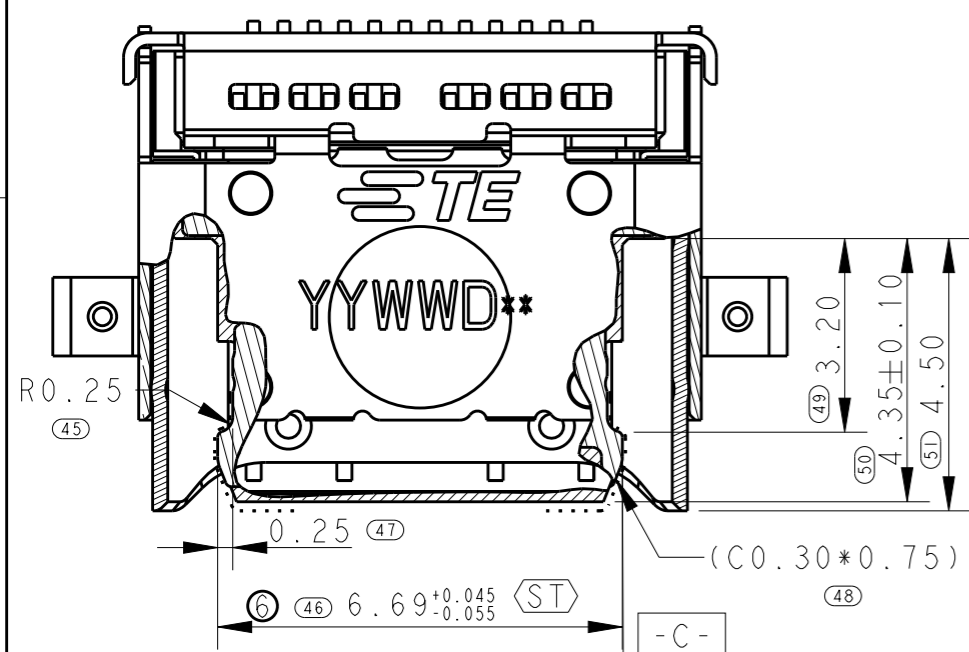

SECTION Y - Y

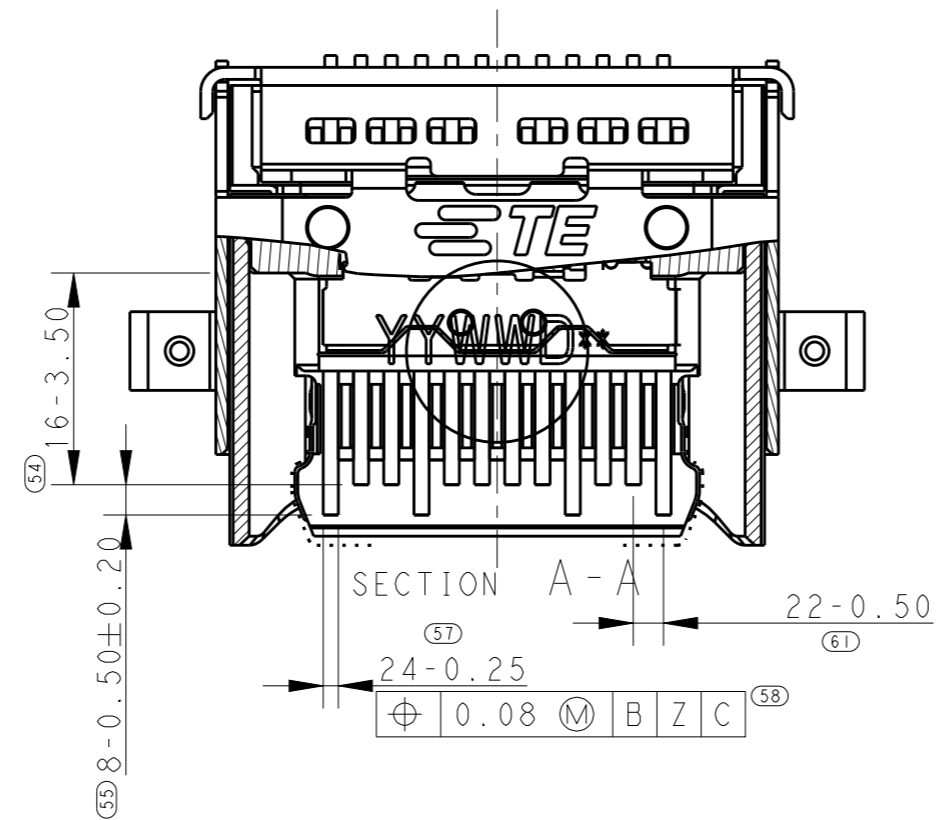

SECTION A - A

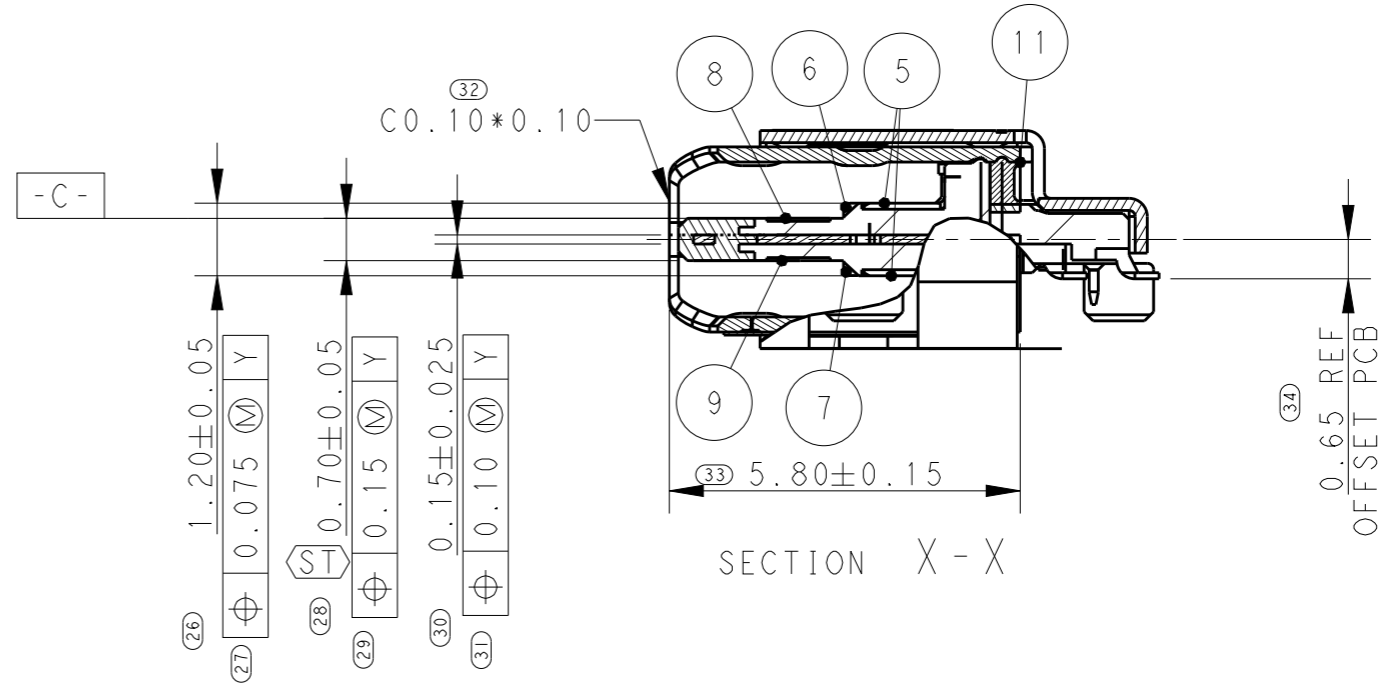
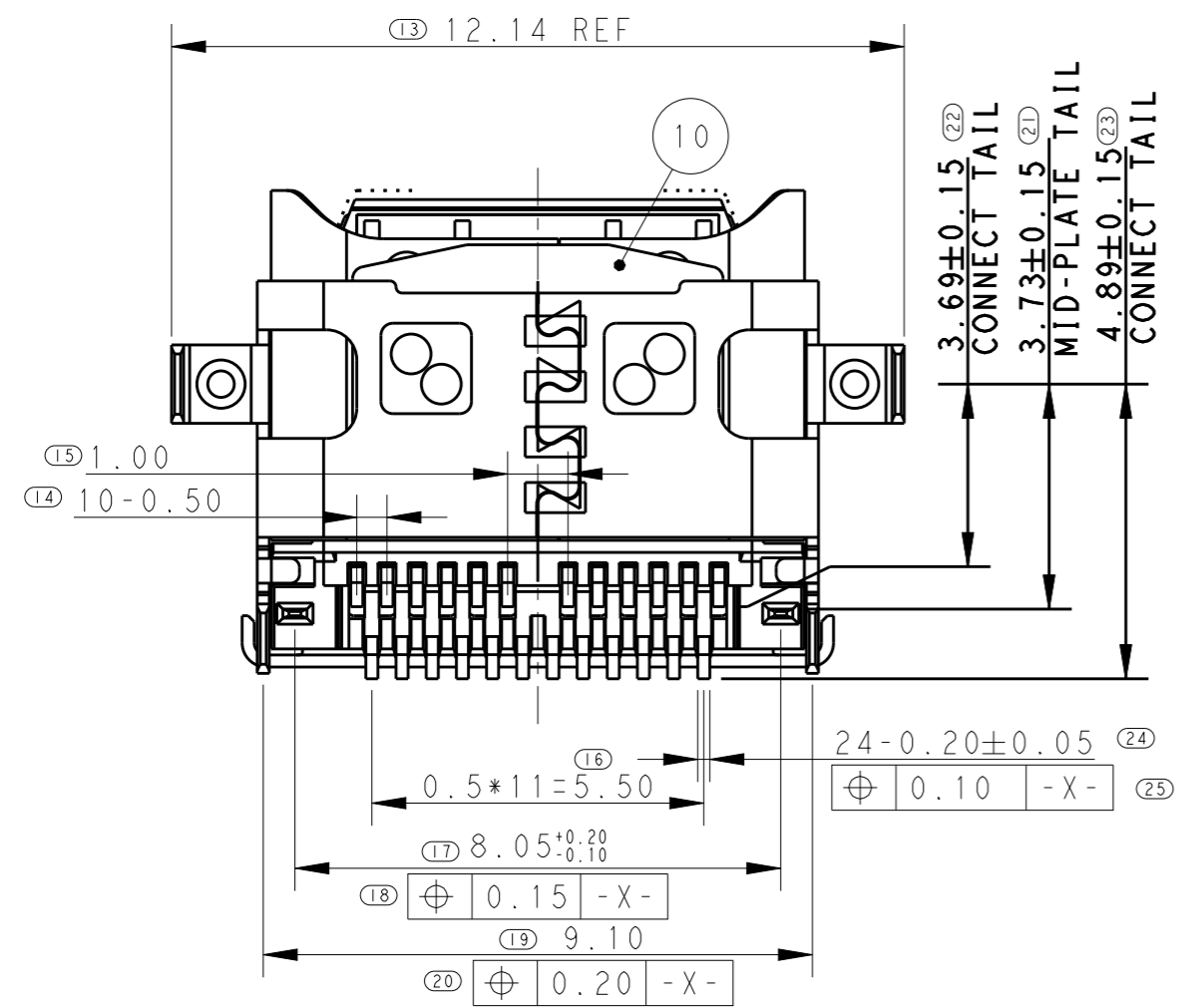

SECTION X - X

THIS DRAWING IS A CONTROLLED DOCUMENT.		DWN S.ZH 18AUG2015	<b>STE</b> TE Connectivity
DIMENSIONS: mm		CHK H.WU 18AUG2015	
TOLERANCES UNLESS OTHERWISE SPECIFIED:		APVD H.WU 18AUG2015	NAME USB C, RECEPTACLE, DUAL ROW SMT, OFFSET 0.65MM
0 PLC ±0.25		PRODUCT SPEC 108-115109-2	SIZE A3
1 PLC ±0.25		APPLICATION SPEC 501-115141-2	CAGE CODE -
2 PLC ±0.25		WEIGHT -	DRAWING NO C-2295018
3 PLC ±0.25		CUSTOMER DRAWING	RESTRICTED TO -
4 PLC ±0.25		SCALE 1:1	SHEET 2 OF 4
ANGLES ±3°			REV B1
FINISH -			
MATERIAL SEE DRAWING			

THIS DRAWING IS UNPUBLISHED. RELEASED FOR PUBLICATION 20  
 © COPYRIGHT 20 BY - ALL RIGHTS RESERVED.

REVISIONS					
P	LTR	DESCRIPTION	DATE	DWN	APVD
-	-	SEE SHEET 1	-	-	-

SHOWN AS; 2295018-2, 1-2295018-2  
 9.10

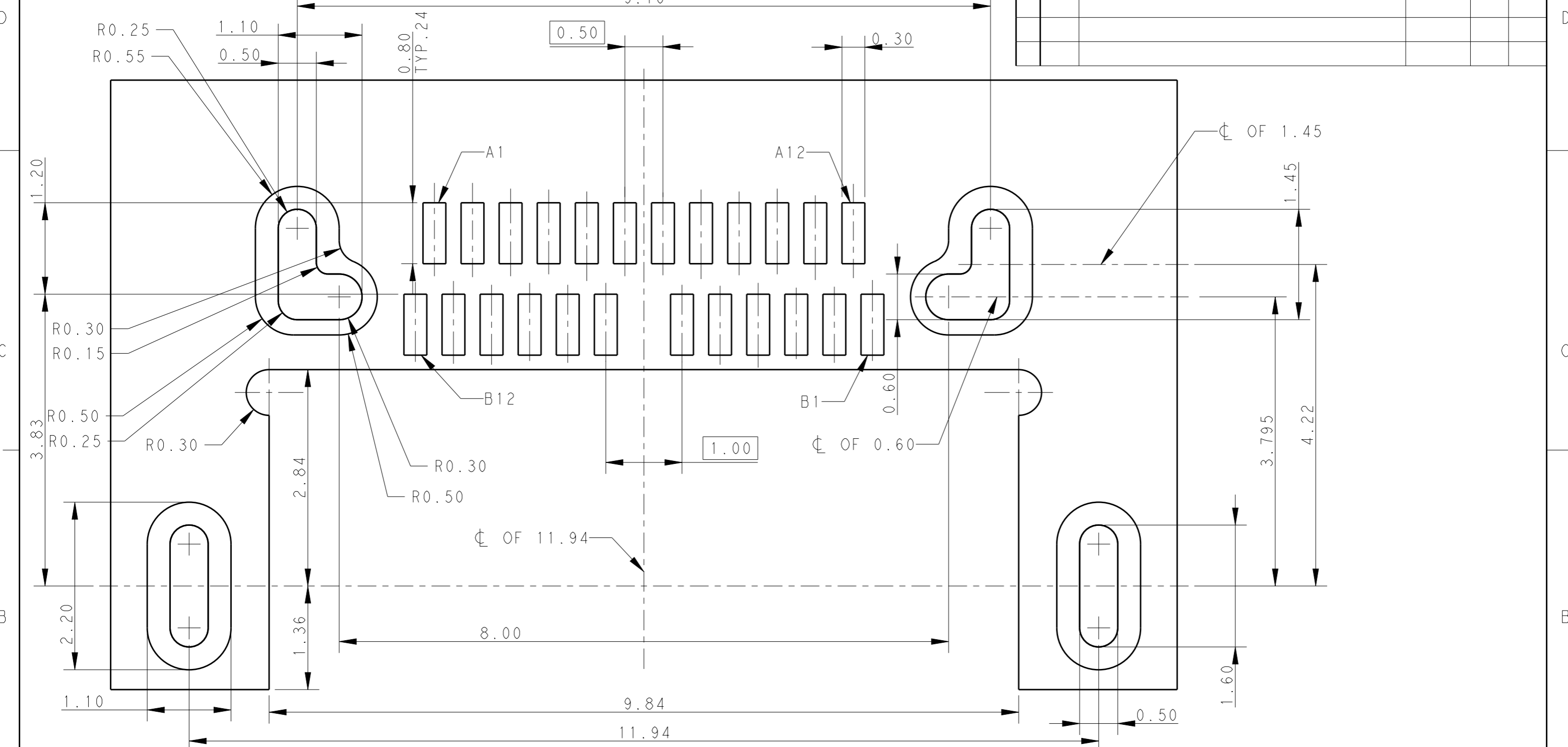

ONLY REFERENCE PCB LAYOUT(TOP VIEW)  
 THICKNESS: 0.80MM  
 GENERAL TOLERANCE: ±0.03

SCALE 20:1

RECEPTACLE PIN LABEL:

A1	A2	A3	A4	A5	A6	A7	A8	A9	A10	A11	A12
GND	TX1+	TX1-	VBUS	CC1	D+	D-	SBU1	VBUS	RX2-	RX2+	GND
GND	RX1+	RX1-	VBUS	SBU2	D-	D+	CC2	VBUS	TX2-	TX2+	GND
B12	B11	B10	B9	B8	B7	B6	B5	B4	B3	B2	B1

THIS DRAWING IS A CONTROLLED DOCUMENT.		DWN S.ZH	18AUG2015	 TE Connectivity
DIMENSIONS: mm		CHK H.WU	18AUG2015	
TOLERANCES UNLESS OTHERWISE SPECIFIED:		APVD H.WU	18AUG2015	
0 PLC ±0.25 1 PLC ±0.25 2 PLC ±0.25 3 PLC ±0.25 4 PLC ±0.25 ANGLES ±3°		NAME USB C, RECEPTACLE, DUAL ROW SMT, OFFSET 0.65MM		
MATERIAL SEE DRAWING		PRODUCT SPEC 108-115109-2		SIZE A3
FINISH -		APPLICATION SPEC 501-115141-2		CAGE CODE -
-		WEIGHT -		DRAWING NO ©-2295018
-		CUSTOMER DRAWING		RESTRICTED TO -
SCALE 1:1			SHEET 3 OF 4	REV B1

THIS DRAWING IS UNPUBLISHED. RELEASED FOR PUBLICATION 20  
 © COPYRIGHT 20 BY - ALL RIGHTS RESERVED.

REVISIONS					
P	LTR	DESCRIPTION	DATE	DWN	APVD
-	-	SEE SHEET 1	-	-	-

SHOWN AS; 2295018-2, 1-2295018-2

CUSTOMER FEED DIRECTION →

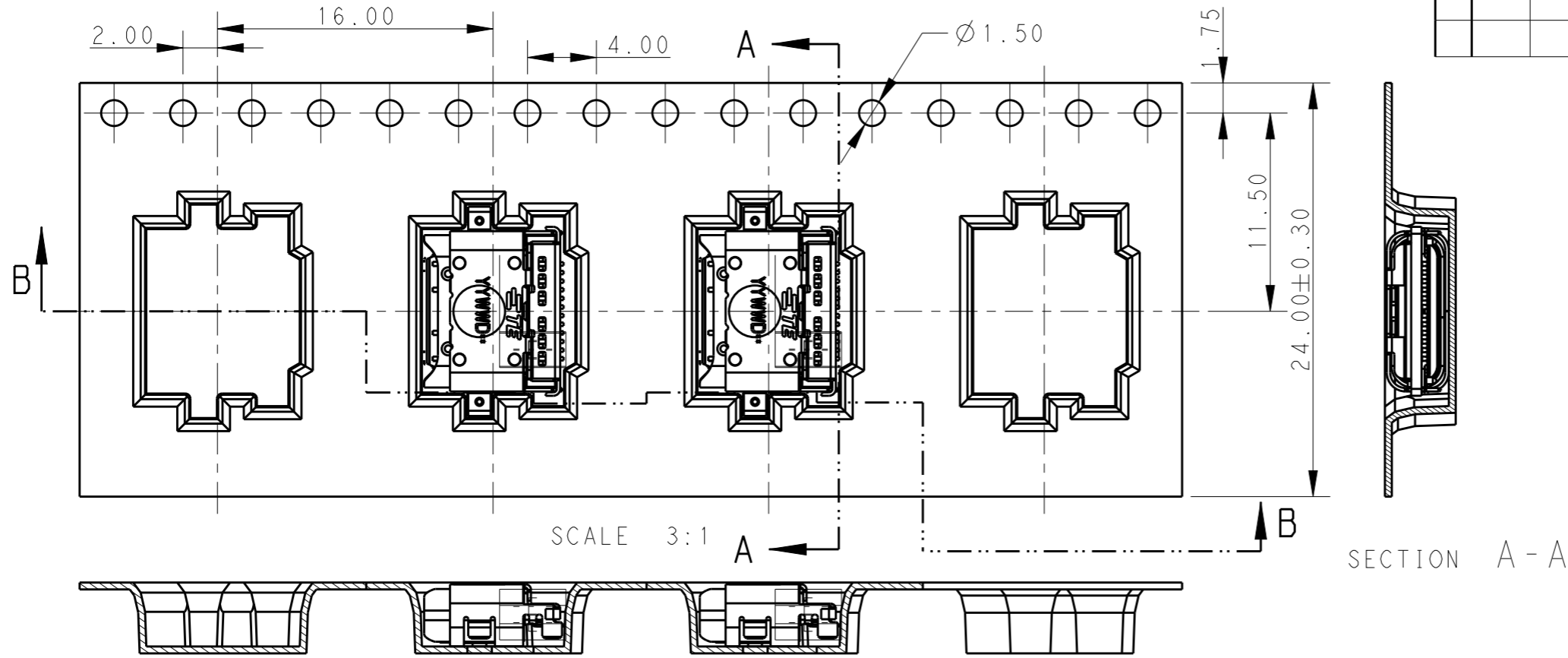

SCALE 3:1

SECTION A-A

SECTION B-B

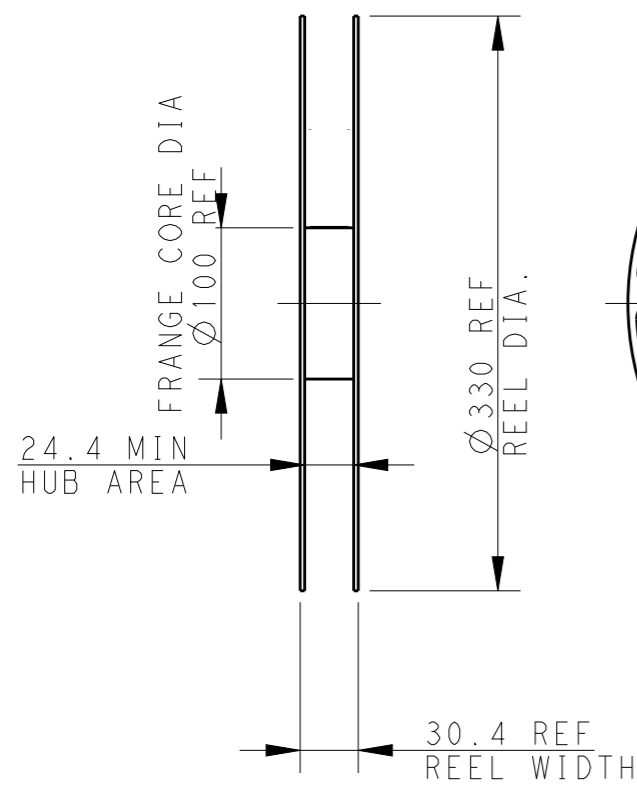

USER PULL OUT DIRECTION →

WITHOUT CHARGE 15PCS REF    WITH PRODUCT CHARGE 900PCS    WITHOUT CHARGE 10PCS REF

THIS DRAWING IS A CONTROLLED DOCUMENT.		DWN S.ZH 18AUG2015		
DIMENSIONS: mm		CHK H.WU 18AUG2015		
TOLERANCES UNLESS OTHERWISE SPECIFIED:		APVD H.WU 18AUG2015	NAME USB C, RECEPTACLE, DUAL ROW SMT, OFFSET 0.65MM	
0 PLC ±0.25		PRODUCT SPEC 108-115109-2	SIZE A3	
1 PLC ±0.25		APPLICATION SPEC 501-115141-2	CAGE CODE -	DRAWING NO C-2295018
2 PLC ±0.25		WEIGHT -	RESTRICTED TO -	
3 PLC ±0.25		CUSTOMER DRAWING	SCALE 1:1	SHEET 4 OF 4
4 PLC ±0.25				REV B1
ANGLES ±3°				
FINISH -				
MATERIAL SEE DRAWING				